

# baabor

[www.baabor.com](http://www.baabor.com)



## lobe screen bucket

# Lobe screen bucket

The 'baabor' lobe screen is an excavation bucket equipped for **screening work**. Hydraulically driven, the bucket sifts the material inside, removing fines smaller than the center distance and retaining larger solids inside. Its profile, similar to that of an excavation bucket, allows all the typical tasks of this type of bucket.

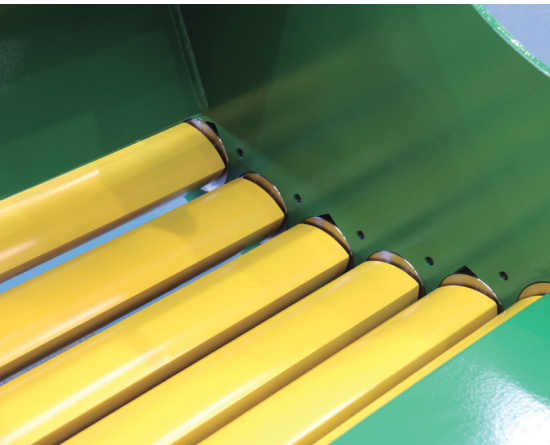
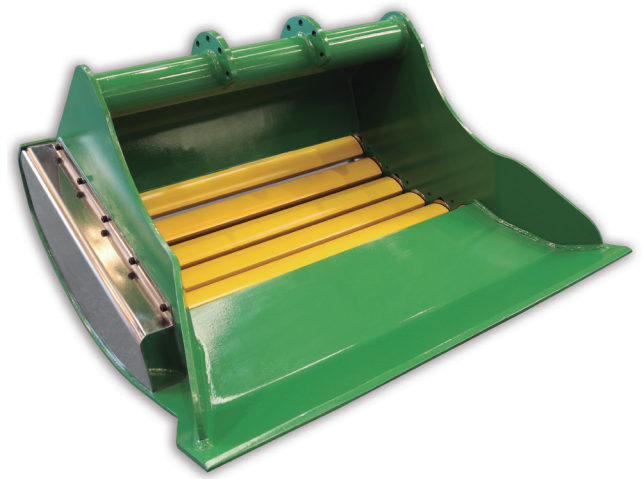

Our **innovative lobe profile system on the screening shafts** goes further than any other shaft screen on the market. With a silent, vibration-free movement, it gently agitates the material inside the bucket. This allows for screening materials sensitive to breakage, such as demolition waste containing bricks, wood, iron pieces, etc., as well as fine construction materials, without crushing any of these..

This feature makes our screen's mechanical requirements very low, which considerably reduces the equipment's weight, and its moving parts are completely maintenance-free.

We could call it "plug and play," as it requires no hydraulic adjustments on the excavators, nor technical assistance for installation and commissioning.

All of the above does not preclude the possibility of aggressive screening, such as rock at a quarry face.

TECHNICAL SPECIFICATIONS		B8.100.e	B16.130.e	B16.160.e
Excavator size	Tn.	8 - 13	14 - 18	18 - 23
Weight (top plate included)	kg	500	820	1.000
Operation pressure	MPa	14 to 18	14 to 18	14 to 18
Maximum operation flow	L/min	50	100	100
Hydraulic circuit		Shear mode	Shear mode	Shear mode
Loading capacity	m <sup>3</sup>	0,4	0,9	1,2
External width (A)	mm	1.340	1.675	1.975
Internal width (B)	mm	1.000	1.300	1.600
Length (C)	mm	1.250	1.260	1.260
Height (D)	mm	800	1.220	1.220
Screening shafts options (e)	mm	8 to 50	8 to 50	8 to 50

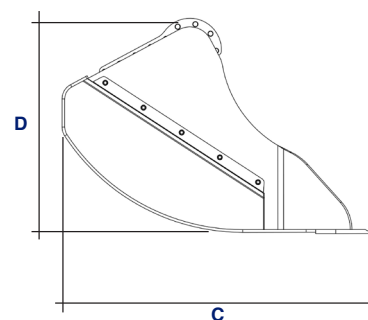
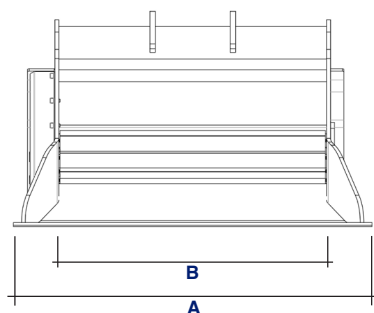

**baabor**

ARRIURDINA, 15. Pol. Ind. Júndiz · 01015 Vitoria-Gasteiz (Álava) - SPAIN · Tel.: +34 945 290 555

Contact: Ricardo Ibáñez · M.: +34 664 413 196 · ricardo@baabor.com

Javier Aracama · M.: +34 629 290 555 · javier@baabor.com

[www.baabor.com](http://www.baabor.com)