

[www.baabor.com](http://www.baabor.com)

# baabor

BORN  
TOUGH



**TB**  
till bar



The new **baabor TB (till bar)** is a subsoiler with the same specifications and materials as its predecessors, though mainly focused on covering the needs for **direct seeding** requested by our customers.

This tool is first used for soil decompaction followed by levelling and homogenising with the **rear smooth roller** for later direct seeding. As with the previous subsoilers, its function is to loosen the soil without altering the different layers and leaving the crop residues in the surface.

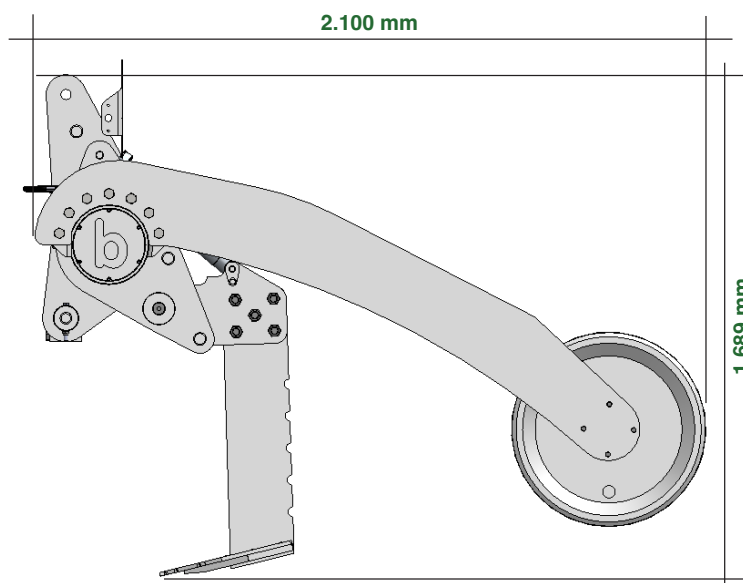
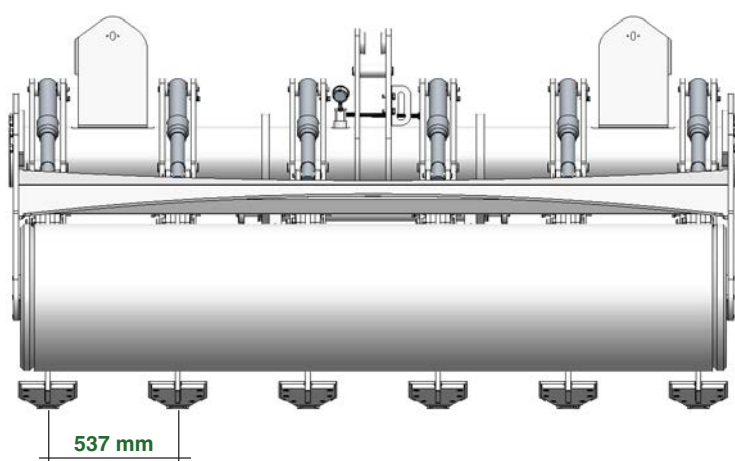
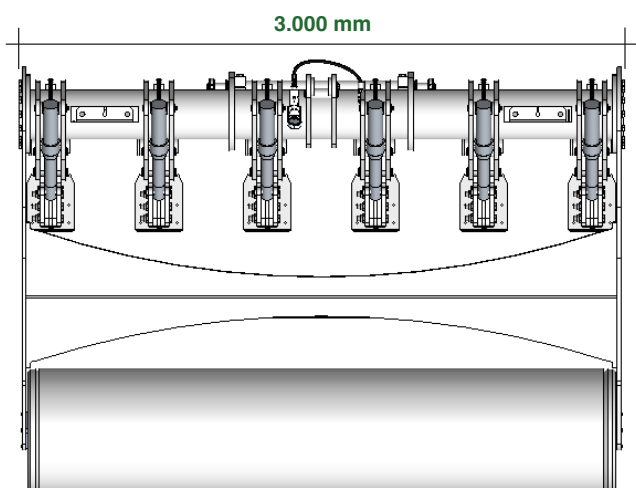

TECHNICAL SPECIFICATIONS		TB320
Working width	mm	<b>3.000</b>
Transport width	mm	<b>3.000</b>
Shank spacing	mm	<b>537</b>
Number of shanks		<b>6</b>
Max. working depth	mm	<b>350</b>
Required power	H.P.	<b>200</b>
Type of coupling	CAT.	<b>III - IV</b>
Approximated weight (with roller)	Kg	<b>2.675</b>